

Traffic Detector - VEK M4D

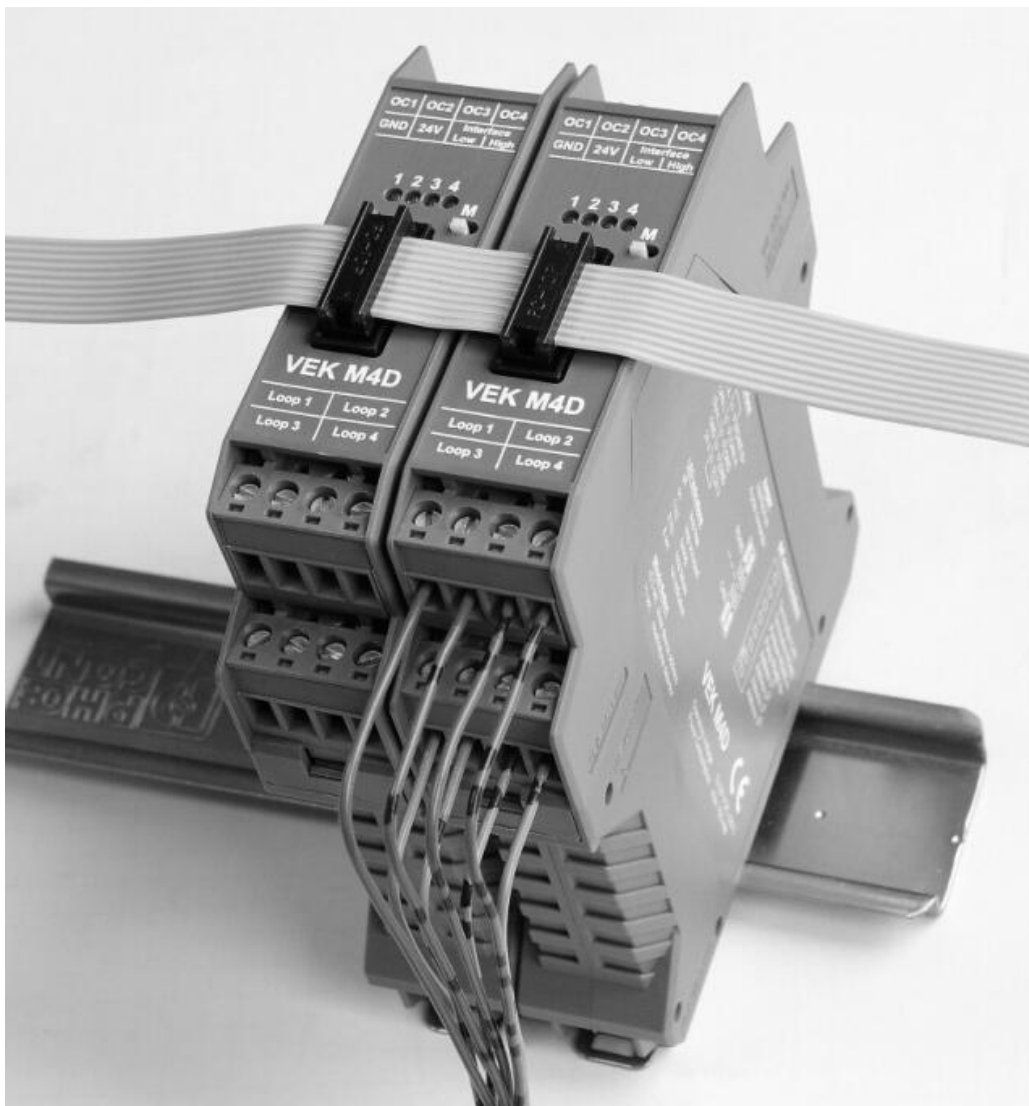

Note

© Copyright 2018 by **FEIG ELECTRONIC GmbH**
Lange Straße 4
D - 35781 Weilburg

The specifications contained in this document may be changed without prior notice.

This edition replaces all earlier editions of the document.

The information in this guide has been compiled to the best of our knowledge and in good faith. *FEIG ELECTRONIC* assumes no liability for the accuracy of the specifications in this guide. In particular *FEIG ELECTRONIC* cannot be held liable for consequential damages resulting from improper installation.

Since errors can never be completely precluded in spite of all our efforts, we are always grateful for corrections and suggestions.

The installation recommendations contained in this guide assume the most favorable circumstances. *FEIG ELECTRONIC* assumes no liability for perfect function of the traffic detector in a foreign system environment.

Photocopying and reproduction of this guide in whole or in part as well as translation into other languages is not permitted without prior written permission from *FEIG ELECTRONIC*. Also prohibited is storage of this guide in whole or in part on modern storage devices for the purposes of further processing in data processing systems.

Please read the user's guide and safety advisories carefully and in full before starting up the traffic detector!

Contents

1	Function Description	4
1.1	Vehicle detection	4
1.2	Calibration	4
1.3	Output options	4
1.4	Multiplexing	5
1.5	Synchronization	5
2	Setting options	7
2.1	Frequency selection	7
2.2	Scan speed / Multiplexing sequence	7
2.3	Sensitivity	8
2.4	Off hysteresis	9
2.5	Hold time	9
2.6	Output modes	9
2.7	Output signal timing	10
2.8	Direction sensing	10
2.9	RS485 interface	12
2.10	CAN interface	12
3	Display and Operation	13
3.1	Display elements	13
3.2	(M)ode key	13
3.3	Factory default setting	14
3.4	Synchronization display	14
3.5	DIP switch	15
4	Housing	16
4.1	Dimensions	16
4.2	Opening the enclosure	17
5	Technical Data	18
6	Connector and Terminal Wiring	19
6.1	Plug terminal: Supply and interface	19
6.2	Loop connections	20
6.3	2x5-pole header for ribbon cable	20
6.4	Outputs	20
6.5	PE connection	20
7	Tips for Planning and Startup	21
8	Scope of Delivery, Accessories	22
9	Safety and Warning Notes	23
10	Appendix	24
10.1	Direction logic „Parking Bay“	24
10.2	Direction detection in various traffic situations	25
11	Notes	30

1 Function Description

The VEK M4D Traffic Detector is a system for inductive sensing of motor vehicles.

Properties:

- 4-channel inductive loop detector
- Compact plastic housing for DIN rail mounting
- Simple installation with ribbon cable connection
- RS485 interface, optional CAN interface
- Reliable vehicle sensing
- Automatic system calibration after power-on
- Continuous compensation of frequency drifts for neutralizing environmental effects
- Sensitivity independent of the loop inductance
- Fixed hold times independent of the loop coverage
- Frequency band setting
- Direction discrimination
- Multiplexing for preventing mutual interference between channels
- Synchronization for preventing mutual interference between multiple detectors
- LED indicator for loop states
- Discriminates busses from automobiles
- Isolation between loop and electronics
- Gas tube arresters for improved overvoltage protection
- Open Collector outputs

Setting options:

- Five fixed frequency bands, independent of loop inductance
- Sensitivity threshold per channel in 256 steps
- Off hysteresis of 20-80% for each channel
- Hold time 1-255 minutes and infinity for each channel
- Detector channels can be turned off
- Output selectable as presence signal, direction signal or group fault message
- Hardware addresses 0-15 set using DIP switches as well as address offset using RS485 interface

1.1 Vehicle detection

An LC oscillator is used to determine whether a metallic vehicle is located in the loop field. The output of each channel is switched corresponding to the set output function.

1.2 Calibration

A calibration is performed each time the detector is powered up or by pressing the button for longer than 1 s. After a power interruption, automatic calibration is performed only if the supply voltage was absent for at least 0.5 s. The calibration time is approx. 1 s if during this time no vehicles have passed through the loop. Longer calibration times are caused by frequency instabilities; their causes must be determined and remedied.

1.3 Output options

The optional outputs are used to output a presence or direction signal, depending on the set output function.

1.4 Multiplexing

The connected induction loops are switched on and off in rapid sequence, so that current flows only through one loop at a time. This prevents mutual interference between the loops of a detector. All loops connected to a detector can thus operate at the same loop frequency.

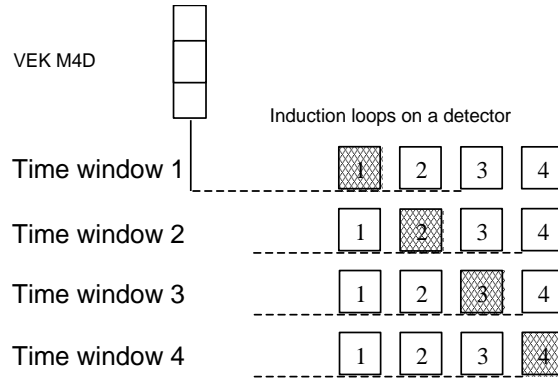

1.5 Synchronization

To prevent mutual interference between induction loops of multiple detectors, the latter can be synchronized with each other using a connection in the front-side ribbon cable. All detectors connected via the synchronous line process the multiplexing sequence synchronously. Only loops which are active in the same time window can affect each other. Assigning the loops to the time windows is done by setting the multiplex sequence.

Note:

- Adjacent loops should be assigned to different time windows.
- Loops in the same time window should be located physically as far away from each other as possible.

a) Example without synchronization:

Loop 2 of Detector Nr. 3 can in the worst case affect *all the loops* of Detectors 1,2,4 and themselves be affected by these loops.

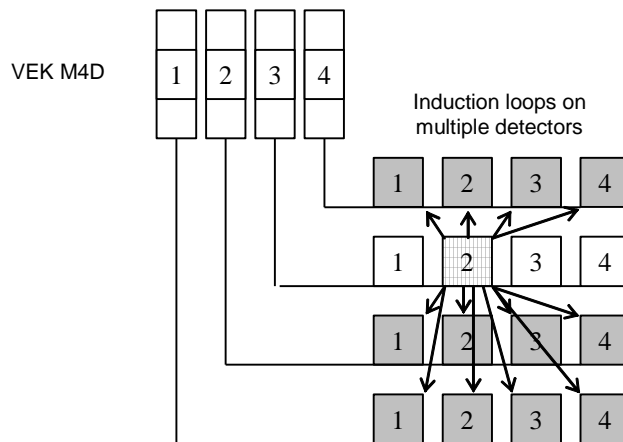

b) Example with synchronization:

Loop 2 of Detector No. 3 can in the worst case only affect loops *in the same time window* of detectors 1,2,4 or be affected by these loops.

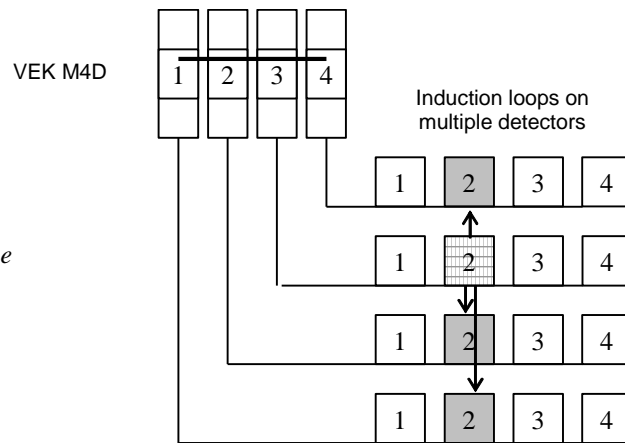

2 Setting options

The settings described in the following are performed either on the RS485 interface or the CAN interface. It is recommended that the system be equipped with an operating unit for setting the detectors. The settings can also be made from a laptop. Setup programs are available from FEIG ELECTRONIC. An appropriate interface converter is also required.

2.1 Frequency selection

The working frequency is set in order to *prevent cross-coupling*.

Cross-coupling may occur with adjacent loops or loop lines on other detectors. It is therefore important that two or more detectors do not operate on the same frequency. A frequency separation of at least 10 kHz should be maintained for neighboring loops which are not connected to the same detector.

The detector operates in five frequency bands:

Band	Frequency range
0	automatic frequency setting <i>(Factory default setting)</i>
1	30 - 40 kHz
2	45 - 55 kHz
3	60 - 75 kHz
4	80 - 100 kHz <i>(Factory default setting)</i>
5	105 - 140 kHz

It is recommended that all four loops of *one* detector be set to the same frequency band. Multiplexing prevents cross-coupling between the 4 loops of a detector.

Note:

For loops whose inductance lies outside the recommended range (see Section 5, Technical Data), the frequency band setting can be restricted. The detector may calibrate to a different frequency than shown in the above table. This is not a problem as long as there is no cross-coupling with other loops. The currently set frequencies should therefore be checked.

If automatic frequency setting is activated, the VEK M4D uses the device address to choose one of the frequency bands 1..4. If automatic frequency band selection is activated, the VEK M4D uses the device address to select one of the frequency bands mentioned above. However, the frequency actually set can deviate from the target frequency, as described above. The frequencies must therefore be controlled.

For additional notes on preventing cross-coupling → see *Section 1.5, Synchronization*.

2.2 Scan speed / Multiplexing sequence

The reaction time of the detector depends on the number of active loop channels and the selectable noise filter. Setting the multiplexer to 2-loop or even single-loop mode doubles the scan speed. Turning off the noise filter can further increase the scan speed, reducing the reaction time from the normal 48ms to 6ms. Note, however, that fast response times also reduce the noise immunity of the system!

Scan mode	Noise filter	Reaction time
4 loops	on	48 ms <i>(Factory default setting)</i>
2 loops	on	24 ms
1 loop	on	12 ms
4 loops	off	24 ms
2 loops	off	12 ms
1 loop	off	6 ms

The default multiplexing sequence is 1-2-3-4. To prevent cross-coupling with neighboring loops of another detector in exceptional cases, you may change the sequence (e.g. 1-4-2-3). → see also *Section 1.5, Synchronization*

It is also possible to turn off individual loops without changing the reaction time. Note that another active loop is assigned to the time window of the loop which is turned off. Here again you need to keep a distance between loops in the same time window in order to prevent cross-coupling.

2.3 Sensitivity

The sensitivity can be selected in 256 steps in a range of 0.005% - 3.188% $\Delta f/f$ for each channel. To minimize noise effects the sensitivity should be set only as high as necessary, i.e., the response threshold value should be set as high as possible.

Parameter value	Response threshold	Sensitivity ($\Delta f/f$)	Level *)
0	4	0.005 % <i>highest sensitivity</i>	5
1	10	0.013 %	4
2	20	0.025 %	
3	30	0.038 %	
4	40	0.050 %	3
5	50	0.063 %	
:	:		
11	110	0.138 %	
12	120	0.150 % <i>(Factory default setting)</i>	2
13	130	0.163 %	
:	:		
41	410	0.513 %	
42	420	0.525 %	1
43	430	0.538 %	
:	:		
100	1000	1.250%	
:	:		
255	2550	3.188 % <i>lowest sensitivity</i>	

*) For comparison the sensitivity levels of the predecessor product VEK M4C are entered in the „Level“ column.

In general the sensitivity setting is adjusted in large steps and the response threshold value selected not higher than 400. Settings over 400 and fine settings are used in applications where distinctions between vehicles need to be made. Thus for example you can selectively detect busses using a large loop having the dimensions 10.0 m x 2.5 m at high setting values.

2.4 Off hysteresis

To prevent a momentary drop-out of the busy signal caused by vehicles such as articulated busses, streetcars, trucks with trailers, etc., it is possible to change the switching hysteresis. Interruption-free detection of critical vehicles is than possible even when the on sensitivity is set low. With the factory default setting the off threshold is 75%.

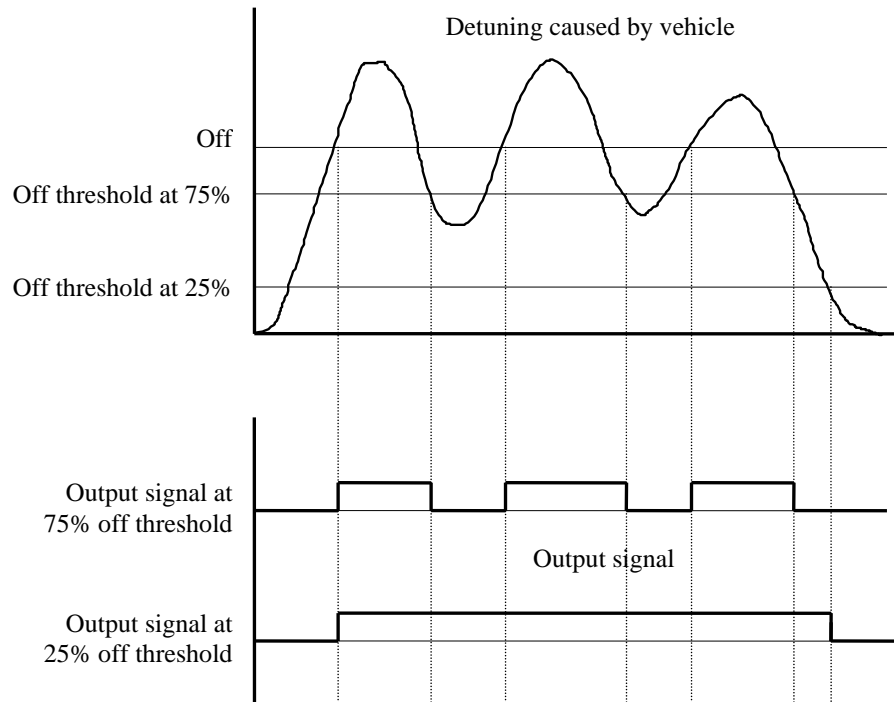

2.5 Hold time

Separate hold times between 1 and 255 minutes can be set on the detector for each channel. Zero minutes means infinite hold time. If the loop of a detector channel is longer than the set hold time, the detector channel recalibrates.

Factory default setting: 20 minutes

2.6 Output modes

The following output modes can be set for the four open collector outputs:

Output mode	Description
Standard output	Normal output mode for presence or direction detection
Group fault message	Output indicates loop faults from all loops
always off	Output always turned off
always on	Output always turned on
Simulation	Output switches constantly, e.g. for testing purposes

Inverted or non-inverted signal output can be selected for all output modes.

In the case of standard output the loop faults of the respective channel can be output together with the logical signal. Which fault is additionally indicated can be set to loop fault (break/short), loop frequency outside frequency band and calibration procedure.

Factory default setting: Standard output,
Signals not inverted,
Respond to loop fault

The interface can be used to temporarily turn the outputs on or off. This allows you to implement control tasks such as controlling traffic lights or variable message signs.

In simulation mode the output is constantly repeated according to the following scheme:

- The signal duration corresponds to the set minimum on duration
- The pause time corresponds to the set on delay. If no on-delay is set (0 ms), an idle time of 20s is assumed.

For the factory set time behavior of the output signals this means a pulse signal of 200 ms duration and an idle time of 20 s.

2.7 Output signal timing

On-delay, minimum on duration and off-delay for the hardware output signals can be set in 100 ms increments over a range of 0...25500ms.

Factory default setting: On-delay 0 ms
Off-delay 0 ms
Minimum on duration 200 ms

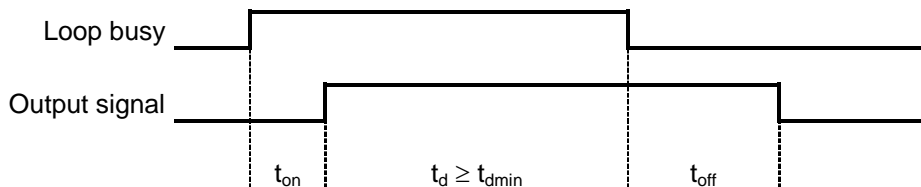

t_{on} : On delay
 t_{off} : Off delay
 t_{dmin} : Minimum on duration
 t_d : Signal duration

2.8 Direction sensing

Complex processing algorithms are built into the detector for direction-dependent sensing of vehicles using double loops. The direction logic generates logical output signals which can be output on a hardware output or over the interface depending on the setting. At the same time the logic signals are autonomously counted in the detector.

The detector incorporates 2 direction logic modules with 2 inputs each (double loops) and 2 outputs (Directions A and B). Assigning of the loops to the logical inputs and assigning of the logical inputs to the open-collector outputs can be user set.

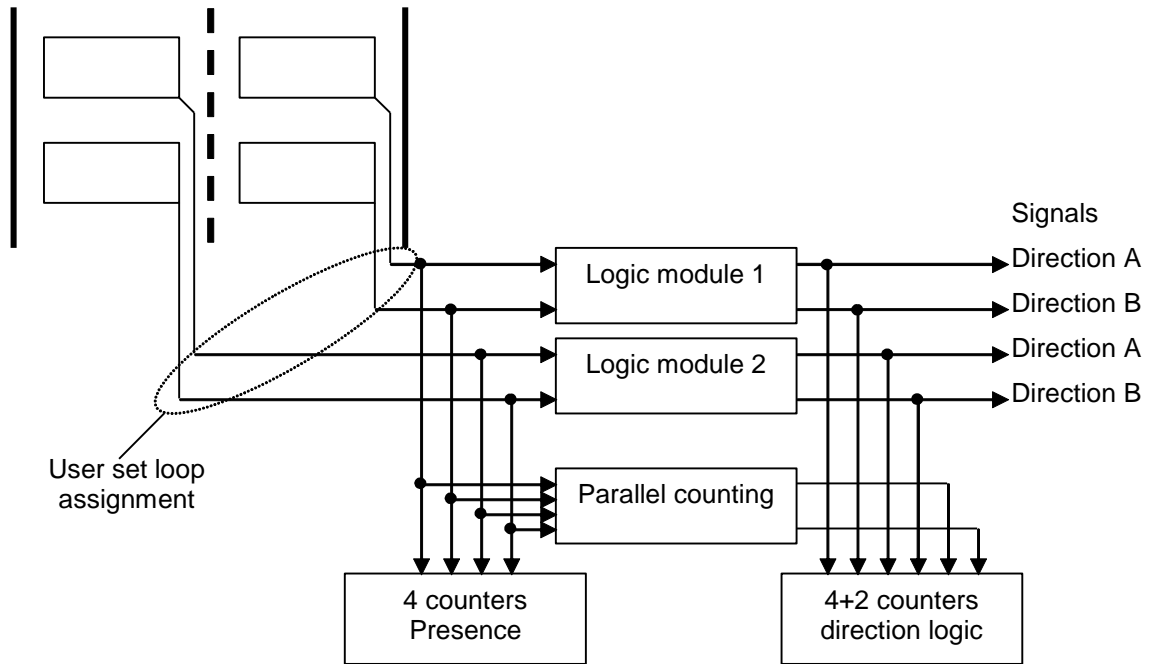

The counter states can be obtained over the interface. In the case of counts in time intervals the count is determined from the counter states at the beginning and the end of the time interval. Note that the counters overflow at 65535 (2^{16}) and then begin over at 0. Resetting the counter states is not recommended, since otherwise vehicles present at the moment of reset are lost. The counter states in the detector are not protected against power loss. For long-term counts either buffer the detectors with an uninterruptible power supply (UPS) or poll the counter states cyclically and save the counts in the host system.

In addition to the double loop counters there is also a 4-loop counter used for counting parallel crossings. These count values can be used as needed in the host system for correcting the sum count for the presumed lane changers.

Depending on the application multiple different processing logics can be set for each of the four logical outputs. The various logics for direction detection are shown in the following. The detailed operation is explained in full in the appendix.

Direction logic	Signal output	Signal off	Remarks
D1 – Duration signal 1	1st loop busy	1st loop left	Signal output in the opposite direction takes place again only if both loops were previously free.
DB - Duration signal for both loops		2nd loop left	
D2 – Duration signal 2	2nd loop busy		
F1 – Wrong-way driver 1 (factory setting)	2nd loop busy	Pulse output with set minimum signal duration (Standard 200ms)	Correct behavior for <i>traffic line</i> and <i>maneuverers</i> . Various response for <i>wrong-way driver</i> situations (see appendix).
F2 – Wrong-way driver 2			Correct behavior for <i>traffic line</i> . There should be no <i>maneuverers</i> .
BS – both loops			Correct behavior for <i>traffic line</i> and <i>maneuverers</i> .
FE – Feig	1st loop left		Capturing of <i>single vehicles</i> and <i>maneuverers</i> . There should be no <i>traffic line</i> .
SF – Loop free	2nd loop left		For brief entrances and exits (see appendix)
PB – Parking bay	direction-dependent		

For all logic cases the first occupied loop determines the count and output direction. For example, if Loop 1 is first occupied, the output and count will be for Direction A.

2.9 RS485 interface

Baud rates: 9.6, 19.2, 38.4 kbaud
Parity: no, even, odd parity

Factory default setting: 9.6 kbaud, even parity

2.10 CAN interface

Transmission rates: 20, 50, 100, 125, 250, 500, 800, 1000 kbps

Factory default setting: 250 kbps

3 Display and Operation

3.1 Display elements

The front panel of the detector contains 4 green LEDs for indicating the respective loop state.

LED behavior in normal operation:

<i>LED</i>	<i>Description</i>
off	Loop free
on	Loop busy or direction pulse
flashes slowly	Frequency calibration running
flashes rapidly	Loop fault (break or short)
Chain	Synchronization indicator in 8s rhythm

Additional LED displays are possible in conjunction with operation using keys.

3.2 (M)ode key

The following functions can be activated by pressing the M-key on the front panel.

<i>M-key</i>	<i>LED display in binary code</i>	<i>Function</i>
1x short	○ ○ ○ ○	Uses LEDs 1-4 to display the hardware address set with DIP switches 1-4.
1x long	○ ○ ○ ○	Generates a hardware reset and before that displays the set hardware address
1x short, 1x long	○ ○ ○ ●	Generates a hardware reset
2x short, 1x long	○ ○ ● ○	Polls the Master (● ○ ○ ●) / Slave (○ ● ● ○)
...		
6x short, 1x long	○ ● ● ○	Resets to factory default settings

The number of short presses of the button is indicated on the LEDs in binary code – left 2^3 , right 2^0

For hardware address ,0' the flashing sequence ○ ● ○ ● / ● ○ ● ○ is output.

The transition between long and short button depression is indicated after 1s by rapid flashing of all LEDs. After an additional second the LED indicators go out to indicate the function is activated. If the button is released sooner, during the flashing phase, the function is cancelled!

3.3 Factory default setting

To restore the factory default parameters, proceed as follows:

- 1) Press button 6x briefly until $\bigcirc \bullet \bullet \bigcirc$ shows on the LEDs.
- 2) Hold button down → After one second all LEDs flash rapidly.
After two seconds the LEDs go out.
- 3) Release button. → The essential detector parameters are now set as follows :

Parameter	Value	Meaning	Remarks
Sensitivity	12	0.15% $\Delta f/f$	On-threshold value 120
Off hysteresis	75	75%	
Hold time	20	20 minutes	
Frequency	0	Automatic frequency	Depending on device address
Hardware output Output mode Inversion Error output	3 0 6	normal output non-inverted Loop and frequency band error	Standard hardware output for loop busy and for loop break, loop short and loop frequency outside the selected frequency band
Direction logic	3	Logic F1(Wrong-way driver 1)	Pulse signal output for both loops busy
Address offset	0 (3)	no offset (or offset 3)	Depends on version
RS485 interface Baud rate Parity Parity detection	3 0 1	9600 baud even on	
CAN interface Baud rate	3	250 kbps	

The default settings for additional parameters can be found in the RS485 protocol description !

3.4 Synchronization display

Correct function of the synchronization of multiple detectors is indicated by the scrolling effect of the LEDs in an 8s rhythm. As the device address increases from left to right, the scrolling LEDs also run from left to right for all synchronized detectors.

Polling of the Master detector is also possible, as described in 3.2 (*M*ode). The Master sends the synchronization signals over the ribbon cable to the other detectors (Slaves). Selection is random.

3.5 DIP switch

The 8-pole DIP switch is used for selecting the device address and for enabling termination for the CAN bus and RS485 interface. The DIP switches are located inside the enclosure. As shipped all DIP switches are in the OFF position.

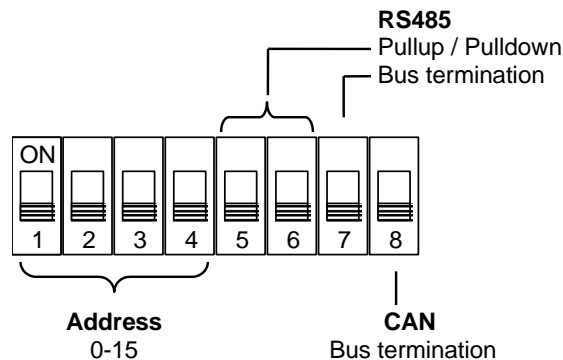

Note! Before startup check all DIP switches for the correct position! Improper setting can damage the interfaces.

3.5.1 Device address

The device address results from the hardware device address set using the DIP switches and the software settable address offset.

DIP switch				Hardware device address
1	2	3	4	
0	0	0	0	0 ¹
1	0	0	0	1
0	1	0	0	2
1	1	0	0	3
0	0	1	0	4
1	0	1	0	5
0	1	1	0	6
1	1	1	0	7
0	0	0	1	8
1	0	0	1	9
0	1	0	1	10
1	1	0	1	11
0	0	1	1	12
1	0	1	1	13
0	1	1	1	14
1	1	1	1	15

$$\text{Device address} = \text{Hardware device address} + \text{Address offset}$$

¹ Note: Device address 0 is reserved for "No Station" address. All devices have to answer for requests with address 0. Therefore device address 0 (hardware device address + address offset) is not allowed!

3.5.2 RS485 interface bus termination

<i>DIP switch</i>	<i>Description</i>
5	470Ω-Pull-up resistor on RS485 B+
6	470Ω-Pull down resistor on RS485 A-
7	Bus termination 120Ω between RS485 B+ and A-

The RS485 bus must be terminated on the front end (control device or repeater) and back end (last detector) with a 120Ω resistor. Set DIP switch 7 to ON in the last detector.

In addition the two RS485 signal lines B+ and A- must be connected once to 5V resp. to GND with a 470Ω resistor each. If this has not been done on the control device or repeater, the circuit can be activated on the last detector using DIP switches 5 and 6.

As shipped the DIP switches are in the ,OFF' position.

3.5.3 CAN bus termination

<i>DIP switch</i>	<i>Description</i>
8	Bus termination 120Ω between CAN-High and CAN-Low

The bus line must be terminated with 120Ω on the first and last station.

4 Housing

4.1 Dimensions

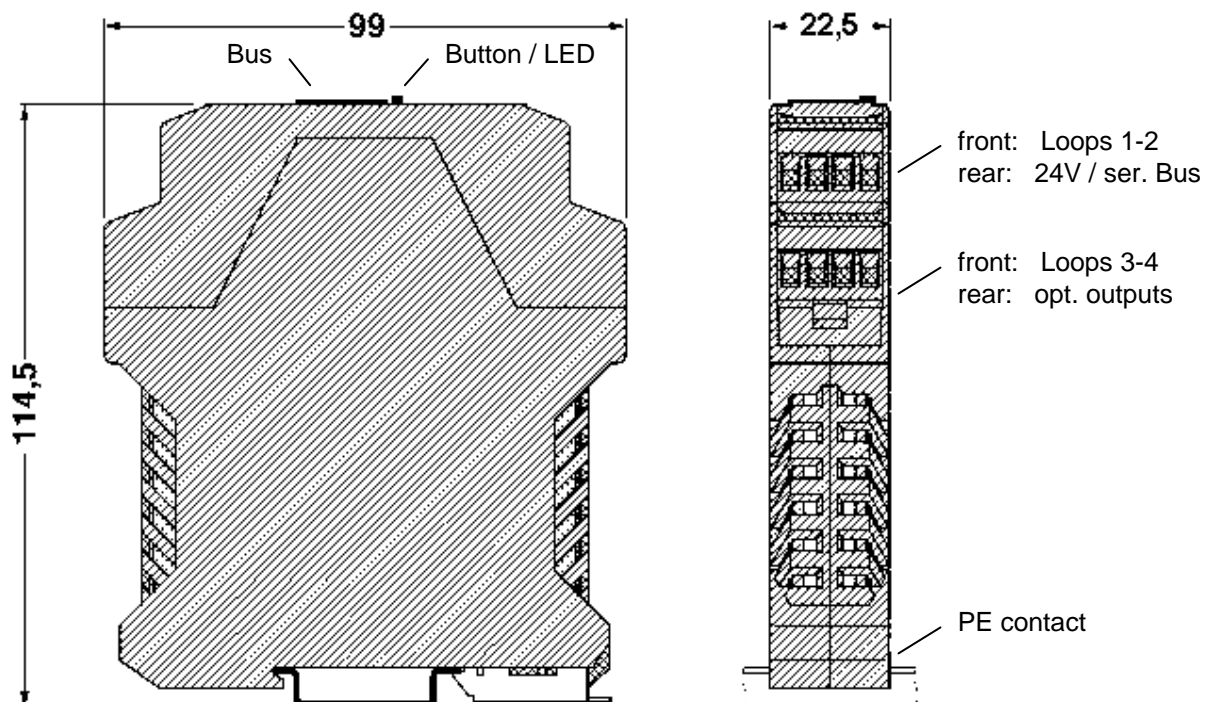

4.2 Opening the enclosure

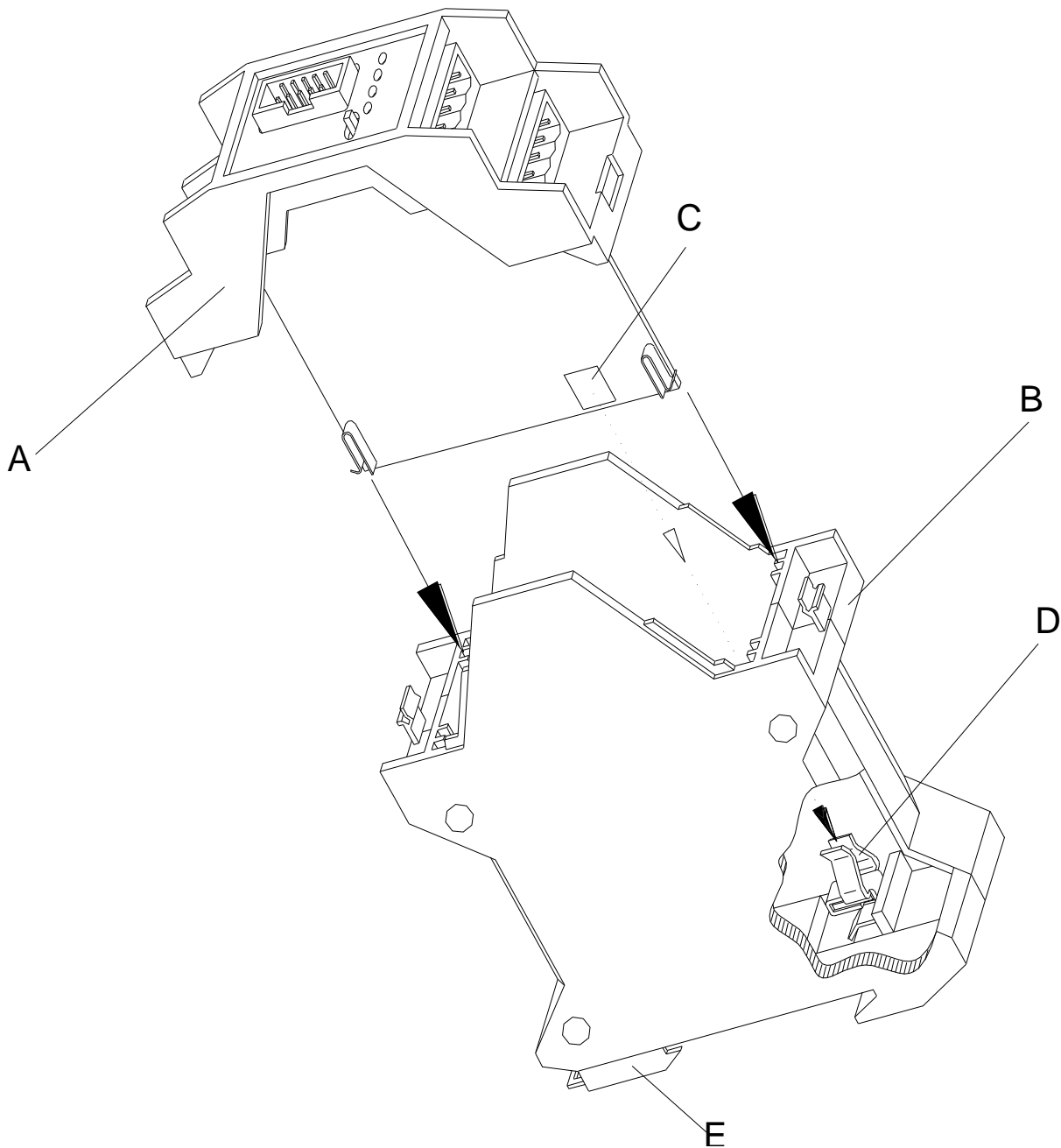

Opening :

- Loosen upper section A by gently pressing with a screwdriver on the side springs at B.
- Remove upper section.

Closing:

- Check orientation, note contact surface C and PE contact D
- Guide circuit board into rear slot
- Latch upper and lower sections into place

5 Technical Data

Supply voltage:	12 to 24 V DC +/- 20 % SELV, limited power sources according to EN 60950-1
Power consumption:	typ. 500 mW, max. 1, W
Ambient temperature	-20 °C to +70 °C
Storage temperature	-40 °C to +85 °C
Humidity	max. 95% non-condensing
Loop inductance range:	25 – 1200 µH
Recommended loop inductance:	80 – 300 µH
Working frequency	30 – 140 kHz
Sensitivity	0,005 % to 3.188 % ($\Delta f/f$) in 256 steps
max. loop cable length	250 m
max. loop internal resistance	20 Ω (incl. cable)
Loop inputs	galv. isolated (1kV), 90V gas tube arresters to PE contact
Cycle time	24 ms
Reaction time	Adjustable using multiplexing parameters 48 ms for standard 4-channel operation: 6 ms for 1-channel operation with reduced noise immunity
Speed limit for motor vehicles	
for presence sensing	> 200 km/h
for direction sensing	> 200 km/h at 2m loop head distance
Outputs (Option)	Low-Side Switch Open Drain, short-circuit protected max. 45 V / 350 mA, $R_{on} \leq 4 \Omega$
Enclosure	Plastic housing, IP 30 for DIN rail mounting Polyamide PA 6.6, blue 22.5 x 99 x 114.5 mm (W x H x D, excl. connector) Integrated function ground contact via DIN rail
Weight	165 g (260 g with packaging)
Connections	
Loops 1-4, altern. CAN-/RS485- Bus and supply voltage, Open Drain outputs 1-4 (Option)	4-pole plug terminals, 0.2 – 2.5 mm ² (AWG 24-14) Phoenix Combicon MSTBT 2.5, blue
Supply voltage, CAN-Bus, RS485-Bus, Synchronization	IDC plug, 10-pole with ribbon cable, front side
Interfaces	
RS 485	<u>9.6 kbaud</u> , 19.2 kbaud, 38.4 kbaud, 8E1 Termination 120 Ω, Pull-up / Pull down 470 Ω switchable
CAN	20 kbps, 50 kbps, <u>100 kbps</u> , 125 kbps, 250 kbps, 500 kbps, 800 kbps, 1 Mbps, High-speed Transceiver to ISO 11898-2 Bus termination 120 Ω switchable

6 Connector and Terminal Wiring

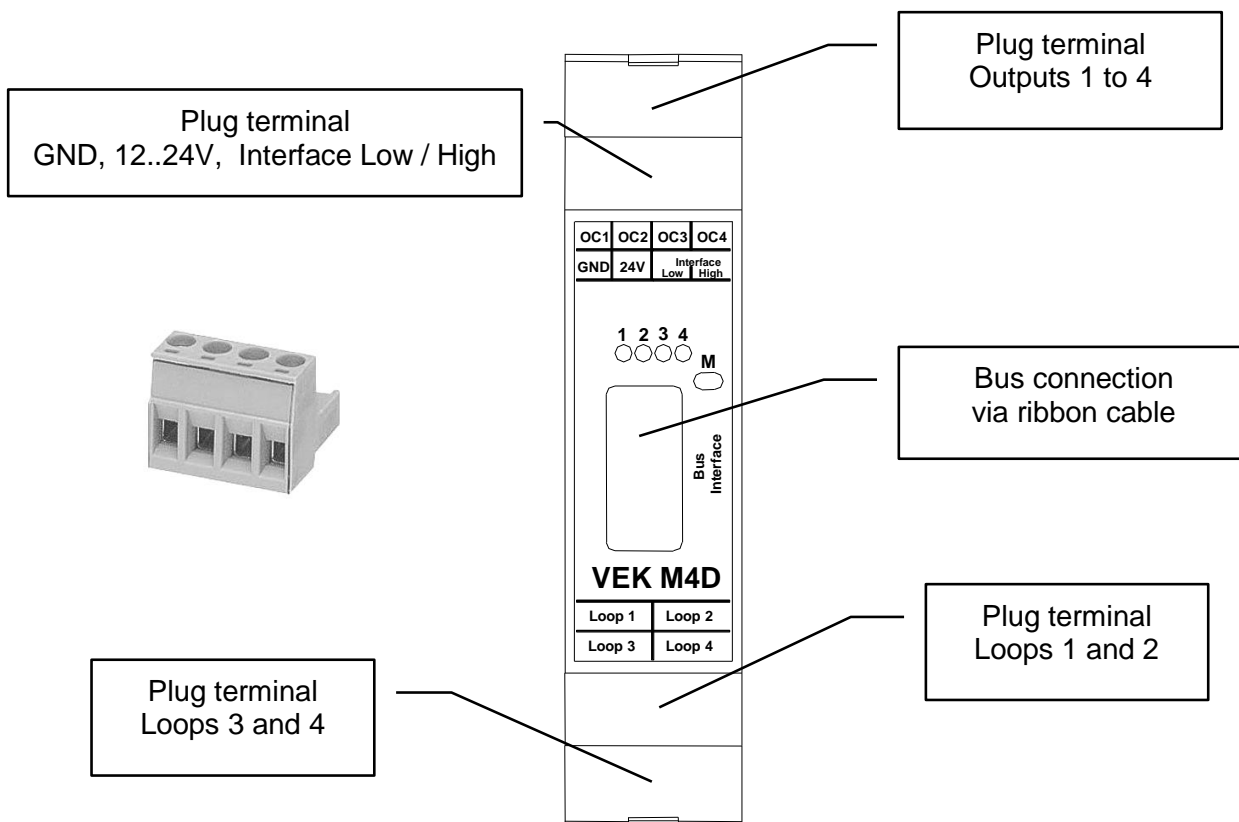

6.1 Plug terminal: Supply and interface



The plug terminal contacts are also connected to contacts of the front-side ribbon cable terminal. This means the supply and interface connections can also be made either using the plug terminal or ribbon cable. When multiple detectors are involved, it is practical to combine the plug terminal and ribbon cable, i.e., connection is made via the plug terminal of one detector, and the additional detectors are connected using ribbon cable (see also section 8, Scope of Delivery, Accessories).

Two jumpers are used to connect the RS485 or CAN bus to the plug terminal. The jumpers are located inside the enclosure. *Both jumpers may be inserted only together for CAN or for RS485 !*

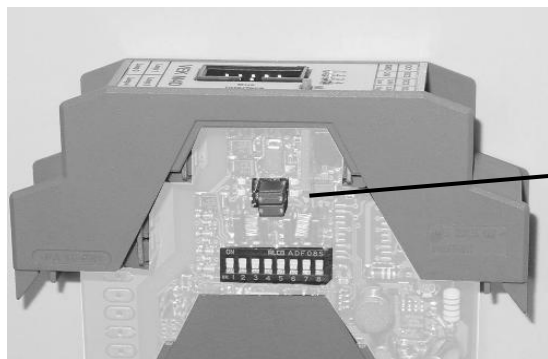

6.2 Loop connections

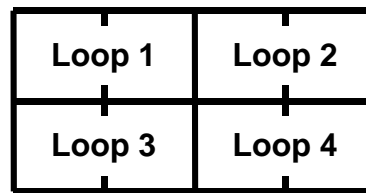

6.3 2x5-pole header for ribbon cable

Front view

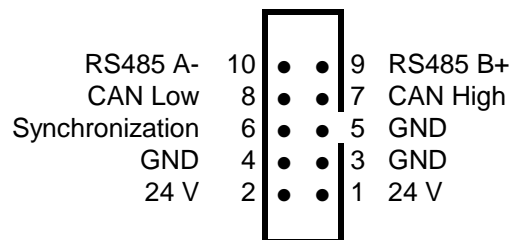

The ribbon cable connection is used to synchronize the detectors with each other and to provide the supply voltage and interface connection. The supply and interface connection to the control device can be made either using the ribbon cable or a plug terminal (see 6.1, Plug terminal: Supply and interface).

6.4 Outputs

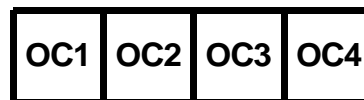

The Open-Collector outputs are short-circuit protected. When a signal is output the outputs switch on (Low active).

6.5 PE connection

Overvoltages on the loop inputs are diverted to PE using the integrated gas tube arrester. For this there is a function ground contact on the enclosure bottom (see also 0 – Part D), which connects the inserted circuit board with the DIN rail. When the circuit board is inserted, be sure that contact surface C fits in the PE contact spring D of the enclosure! The DIN rail must be connected to PE in the system with low impedance !

Noise immunity of the M4D cannot be guaranteed without a PE connection to the DIN rail !

7 Tips for Planning and Startup

- The mounting rail must be grounded. → 6.5, PE connection
- As delivered the detector address 0^1 (3)² is set. Before starting up, set all detectors which will be operated on a common interface to different addresses. → 3.5.1, Device address
- RS485 and the CAN interface are to be wired on the front and back end according to the respective specification.

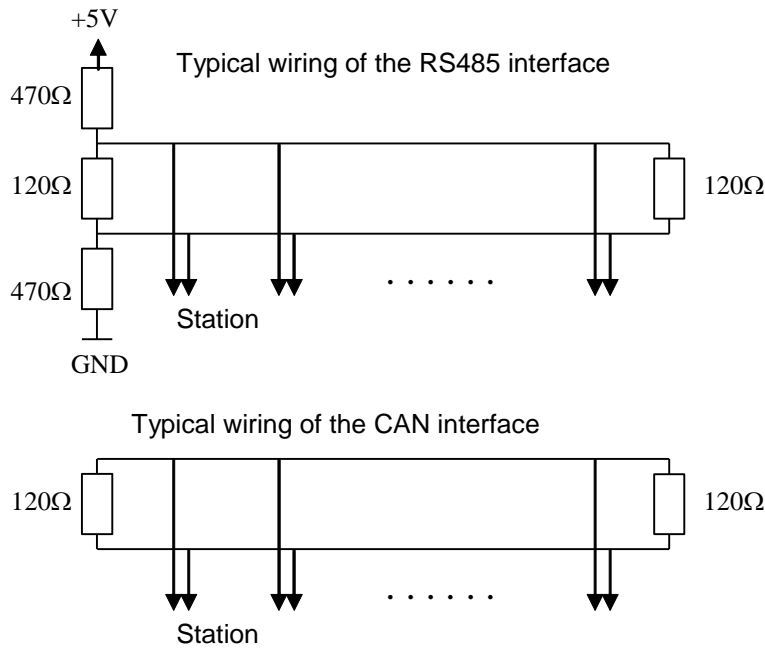

The resistances shown are built into the detector and can be enabled using DIP switches.

→ 3.5.2, RS485 interface bus termination

→ 3.5.3, CAN bus termination

- Neighboring loops are not allowed to be operated in the same time window. As early as the planning stage, be sure that neighboring loops which are not connected to the same detector are assigned different channel numbers. Otherwise the multiplexing sequence will have to be changed at startup.
 - 1.4, Multiplexing
 - 1.5, Synchronization
 - 2.2, Scan speed / Multiplexing sequence
- The loops of a detector are generally set to the same frequency band. Neighboring loops or loops from neighboring detectors should be set to different frequency bands.
 - 2.1, Frequency selection
- For a loop whose inductance lies outside the recommended range the frequency setting possibility is limited. Use special care in making the frequency setting at startup.
 - 2.1, Frequency selection
- The sensitivity of the detectors should be set only as high as necessary. Higher sensitivity settings increase the risk of spurious triggering.
 - 2.3, Sensitivity
 - 2.4, Off hysteresis

¹ Note: Device address 0 is reserved for "No Station" address. All devices have to answer for requests with address 0. Therefore device address 0 (hardware device address + address offset) is not allowed!

² depending on device variant

8 Scope of Delivery, Accessories

The detector is available as a single unit or in a cost-effective 10-pack.

The **single unit** includes four 4-pole plug terminals. This allows you to make all the connections including the serial interface.

For larger systems the connection between the detectors is generally made using a ribbon cable. Therefore the **10-pack** includes only the terminals for the loop connections. Additional connection parts must be ordered depending on which connection option is selected.

What you need:

- For connecting multiple detectors together a 10-pole ribbon cable with a corresponding number of spring action contacts
- For the supply voltage and communications interface either a plug terminal or a longer ribbon cable per system
- If using the open collector outputs an additional plug terminal per detector

The following accessory sets are available:

- **VEK M4D – Wiring Set**
Contents: 4 plug terminals, configured 1m ribbon cable with 16 spring action contacts and an additional spring action contact
The ribbon cable is trimmed to length by the user for the number of detectors. If the power is provided through the plug terminals this set allows you to equip e.g. 4 systems with 4 detectors each. Using the additional spring action contact you can alternatively provide power directly through the ribbon cable. Additional plug terminals are required if using the detector outputs!
- **VEK M4D – 10 accessory plug terminals**
For additional connections or as a spare part for the loop connections

9 Safety and Warning Notes

- The device should only be used for the applications described by the manufacturer.
- Please keep this operation instruction always accessible and hand it over to every user.
- Inadmissible modifications to the device, use of repair parts and supplementary equipment which are not sold or recommended by the manufacturer can cause burning, electric shock and injuries. Therefore the manufacturer has no liability and this excludes all demands of warranty.
- The warranty regulations of the manufacturer are valid in the version of the purchase date for that device. There is no liability for not suitable, wrong manual or automatic adjustments also regarding no suitable applications of the device.
- Repairs may only be made by the manufacturer.
- The power supply must fulfill the requirements for SELV and limited power sources according to EN 60950-1.
- All connections, the start-up, maintenance, measurements and adjustment operations to the detector have to be made from electrical specialists who have special know-how in the prevention of accidents.
- For the use of devices which have contact to electrical power, please pay attention to the valid security instructions and all prevention orders of fire and accidents.
- Observe valid VDE regulations when handling devices that are exposed to electrical voltage. In particular, but not limited to, these are VDE 0100, VDE 0550/0551, EN 60335 (VDE 0700), EN 60065 (VDE 0860), EN 50110 (VDE 0105), as well as the fire and accident prevention regulations DGUV.
- The user is responsible for an installation, which has conformity to all technical rules in the country where the device is mounted, and also to all regional valid orders. For that the dimension of cabling, fuse protection, connection to ground, switch off, disconnection, isolation controlling and the protection for overload current have to be regarded in detail.
- The detector can not be used as a security device regarding to the security instructions of electrical machines. Using in systems with high danger potential it is necessary to include additional protection devices!
- All work on the device must be carried out in accordance with the national electrical codes and regional regulations.
- The device must not be used as a safety unit in accordance with the Machinery Directive 2006/42 / EC, the Construction Products Directive 305/2011/EU or any other safety regulation. In systems with potential risks, additional safety equipment is required!

10 Appendix

10.1 Direction logic „Parking Bay“

This direction logic is used for short entrances and exits. This logic suppresses compromising of the count by cross-traffic on Loop 1. This means it is non-critical whether Loop 1 is placed in the passing lane or in the maneuvering area.

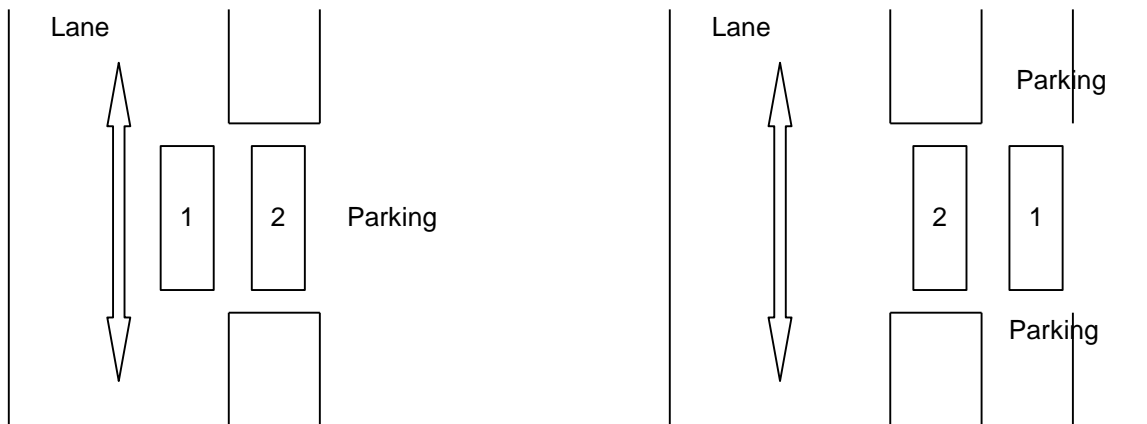

The placing of the loops depends on which travel direction backups are anticipated in. In travel direction 1 → 2 no backups are permitted! In travel direction 2 → 1 even vehicles in traffic line situations are correctly counted, whereby the vehicle gap must always enable a loop.

Logic for travel direction 1 → 2

- The counter pulse arrives when both loops have been fully traversed
- Correct count for individual vehicles
- Correct count for maneuvering as well
- Traffic jam situation and traffic lines may not occur for travel direction 1 → 2!

Logic for travel direction 2 → 1

- The counter pulse arrives as soon as Loop 2 is left in the direction of Loop 1
- Correct count for cross-traffic as well
- Correct count for traffic lines
- Correct count even for maneuvering of a single vehicle
- No maneuverers are allowed within a traffic line!

10.2 Direction detection in various traffic situations

Various traffic situations are shown in the following for Loops 1 and 2. The evaluation of the direction signal is performed in the same manner in the reverse direction of travel as well for Loops 3 and 4 or other loop combinations.

Explanations for the table:

xx Direction logic, gray = logic with incorrect count in this traffic situation.

Imp → Direction pulse

on → Continuous signal on

$\overline{\text{Imp}}$ → Direction pulse in the opposite direction





$\overline{\text{on}}$ → Continuous signal off

The direction signal is output on the channel of the first loop to be traversed.

10.2.1 Single vehicle

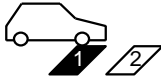
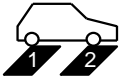
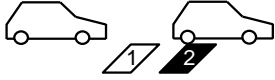
	D2	D1	DB	F1	F2	FE	SF	BS	PB	
									Ri1	Ri2
		on	on							
	on	---	---	Imp	Imp			Imp		
	---	off	---			Imp				Imp
	off		off				Imp		Imp	

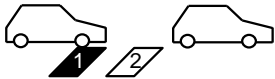
10.2.2 Traffic line

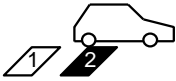
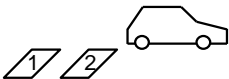
	D2	D1	DB	F1	F2	FE	SF	BS	PB	
									Ri1	Ri2
		on	on							
	on	---	---	Imp	Imp			Imp		
	---	off	---			Imp				Imp
	---	on	---							
	off	---	---						Imp	
	on	---	---	Imp	Imp			Imp		
	---	off	---			Imp				Imp
	off		off				Imp		Imp	

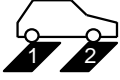
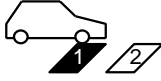
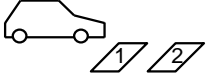

10.2.3 Wrong-way driver 1

	D2	D1	DB	F1	F2	FE	SF	BS	PB	
									Ri1	Ri2
		on	on							
	on	---	---	Imp	Imp			Imp		
	off	---	---							
		off	off	Imp	Imp					

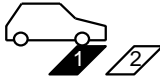
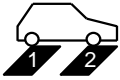
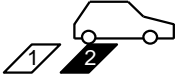
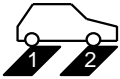
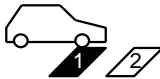
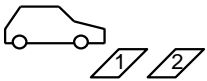

10.2.4 Wrong-way driver 2

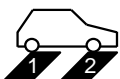
	D2	D1	DB	F1	F2	FE	SF	BS	PB	
									Ri1	Ri2
		on	on							
	on	---	---	Imp	Imp			Imp		
	---	off	---			Imp				Imp
	---	on	---							
	off	---	---						Imp	
		off	off		Imp					

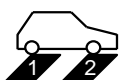
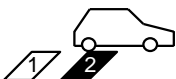
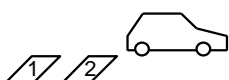
10.2.5 Maneuverer 1

	D2	D1	DB	F1	F2	FE	SF	BS	PB	
									Ri1	Ri2
		on	on							
	on	---	---	Imp	Imp			Imp		
	off	---	---							
	on	---	---							
	---	off	---			Imp				Imp
	off		off				Imp		Imp	

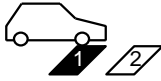
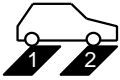
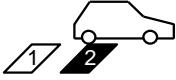
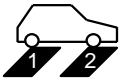
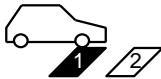
10.2.6 Maneuverer 2

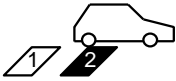
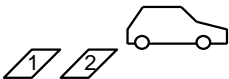
	D2	D1	DB	F1	F2	FE	SF	BS	PB	
									Ri1	Ri2
		on	on							
	on	---	---	Imp	Imp			Imp		
	---	off	---			Imp				Imp
	---	on	---							
	off	---	---						$\overline{\text{Imp}}$	
	on	---	---	Imp	Imp			Imp		
	---	off	---			Imp				Imp
	off		off				Imp		Imp	

10.2.7 Wrong-way driver in traffic line

	D2	D1	DB	F1	F2	FE	SF	BS	PB	
									Ri1	Ri2
		on	on							
	on	---	---	Imp	Imp			Imp		
	---	off	---			Imp				Imp
	---	on	---							
	off	---	---						Imp	
		off	off		Imp					

10.2.8 Cross-traffic

	D2	D1	DB	F1	F2	FE	SF	BS	PB	
									Ri1	Ri2
		on	on							
	on	---	---	Imp	Imp			Imp		
	---	off	---			Imp				Imp
	---	on	---							
	off	---	---						Imp	
		off	off		Imp					

All logics except for PB in Direction 1 will result in incorrect counts in this traffic situation, since they count in instead of out.

11 Notes
